

PRODUCT SPECIFICATIONS:

1. STANDARD LENGTH 10' [3 m] GRID PATTERN
2" [50 mm] x 4" [100 mm] Wire diameter: 0.232 [6mm]
2. TEMPERATURE CLASS: -45°C (-49° F) TO 150°C (302° F)
3. ALL EXPOSED FABRICATED EDGES ARE TAPERED AT 20°
4. INSTALLATION OF THIS PRODUCT MUST BE IN ACCORDANCE WITH CHALFANT MANUFACTURING COMPANY'S RECOMMENDED PROCEDURES & PRACTICES

TABLE 1

Part Number	Finish	Weight	
		Lbs	Kg
WMST612S	Electro-Galvanized	28.60	13
WMST612G	Hot-Dipped Galvanized	30.34	13.8
WMST612T	Stainless Steel (304)		

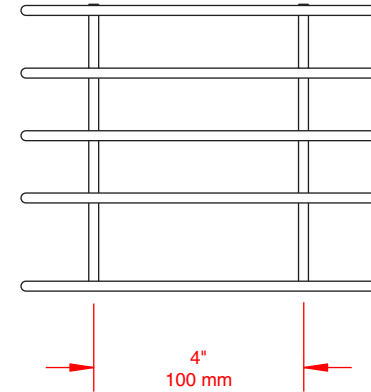
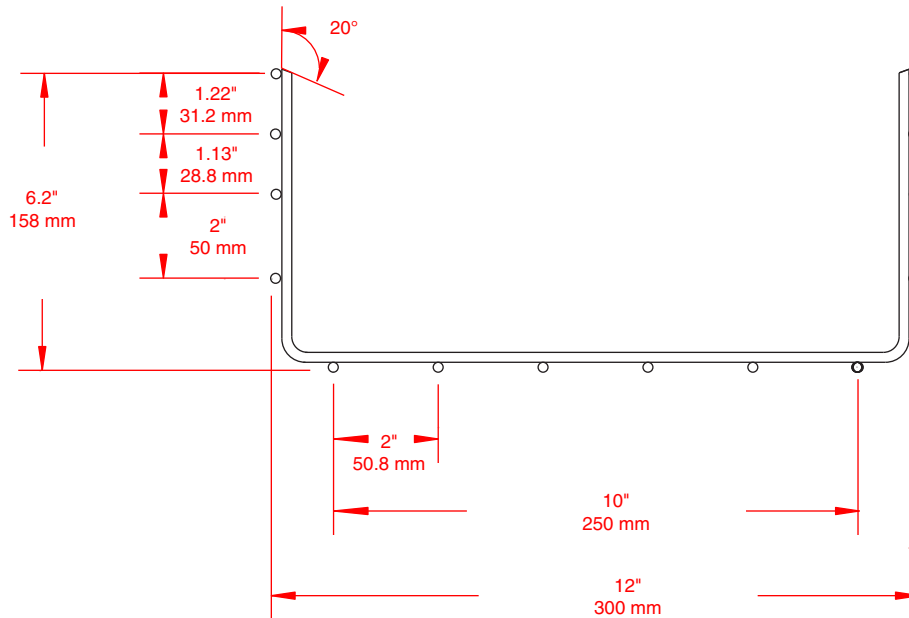

THIS DOCUMENT CONTAINS PROPRIETARY INFORMATION AND IS THE PROPERTY OF CHALFANT MANUFACTURING COMPANY. THE CONTENTS OF THIS DOCUMENT SHALL NOT BE DISCLOSED, COPIED AND OR PUBLISHED WITHOUT THE WRITTEN CONSENT OF CHALFANT MANUFACTURING COMPANY.

FILENAME: CDWMST0612S		 50 Pearl Rd, Brunswick, OH. 44212 Phone: (800) 365-0228 Fax: (330) 273-8149 www.chalfantcabletray.com	6" x 12" WIRE MESH CABLE TRAY
SCALE: AS NOTED			
DRAWN: J.A.B	02/05/00	PART NO. : AS IN TABLE	DRAWING NO. : WMST0612
APPROVED: -	C.D.: 0001		
REV. -	-	SHEET 1 OF 1	